

Handi Felting Foot Kit

HG00272

PACKAGE CONTENTS

- (1) Felting Foot
- (1) Needle Body
- (1) Felting Needle 36 Gauge PKG of 10
- (1) Felting Needle 38 Gauge PKG of 10
- (1) Felting Needle 40 Gauge PKG of 10
- (9) Screw - M3 X 4 SKS C ZN
- (2) Screw - M2 X 10 SKC ZN
- (1) Needle Felting Plate
- (1) Clamp - Needle Bar Felting Unthreaded
- (1) Clamp - Needle Bar Felting Threaded
- (1) Instruction Sheet

YOU WILL ALSO NEED

- 2.5mm hex tool (This tool came with your Handi Quilter machine.)

➔ **IMPORTANT:** If your machine didn't come already equipped with the Handi Feet mount, you need to convert from the original hopping foot to the Handi Feet mount using the Handi Feet Conversion Kit (QM0084).

PREPARE MACHINE AND INSTALL THE SPECIAL NEEDLE PLATE

1. Turn off the machine power and unplug the machine.
2. Remove the needle from the machine.
3. Remove the needle clamp screw from the machine.
4. Remove the hopping foot from the machine.
5. Remove the needle plate from the machine.

✎ **NOTE:** Needle plates vary per machine. Please follow the directions for the needle plate orientation to make sure installation is correct.

NEEDLE PLATE ORIENTATION

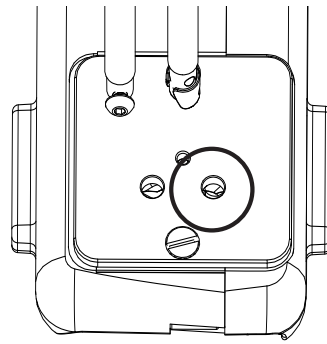

The needle plate is installed with the two holes to the front of the machine as shown. The felting needles will go through the right hole in the front of the felting needle plate

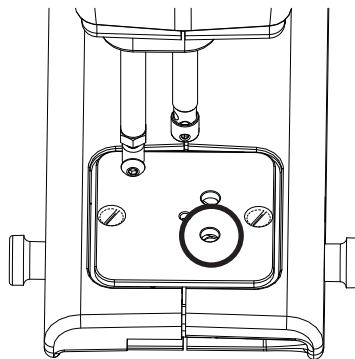

The needle plate is installed with the two larger holes to the right side of the machine as shown. The felting needles will go through the front hole at the right of the felting needle plate.

INSTALL THE FELTING FOOT

Install the Felting Foot onto the machine.

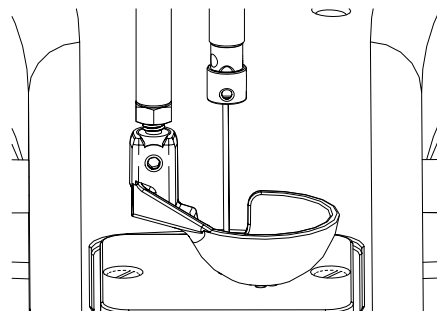

INSTALL NEEDLES INTO THE NEEDLE BODY

Install up to five felting needles into the needle body. Using the provided 1.5mm hex driver tool firmly tighten the set screws onto each needle. Do not over tighten.

✎ **NOTE:** Ensure the needles are fully inserted into the needle body.

✎ **NOTE:** The needles are very close together. A small jeweller's pliers or a tweezers (not included) are helpful to install the needles.

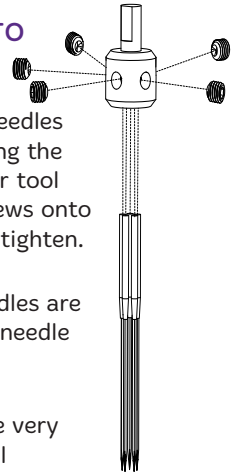

INSTALL NEEDLE BODY INTO THE CLAMP, THREADED SIDE

Install the needle body into the threaded side of the felting clamp (QM1015). The threaded side has a hole for the felting needle body shank with flat and a set screw that tightens onto the flat of the shank.

Using the provided 1.5mm hex driver tool firmly tighten the set screw onto the flat of the needle body shank.

✎ **NOTE:** Ensure that the shank is inserted fully into the clamp and that the set screw tightens onto the flat of the shank.

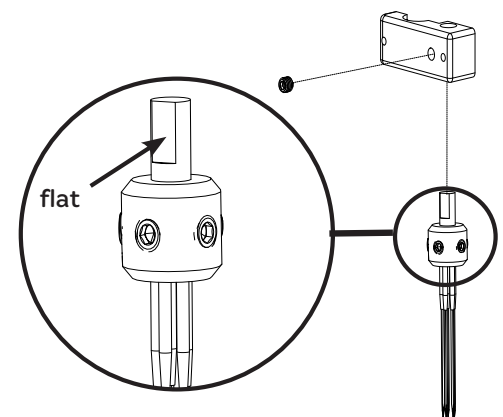

CONTINUE ON BACK OF PAGE

 **Handi Quilter®**

Designed by a Quilter, for Quilters.®

www.HandiQuilter.com • 1-877-MY-QUILT (697-8458)

©Handi Quilter, Inc.

Handi Felting Foot Kit

Use the Handi Felting Foot Kit to transform your HQ longarm into a felting machine with infinite possibilities! No thread required to felt wool and silk fibers into appropriate base fabrics. Go to www.HandiQuilter.com/FeltingFootKit for more ideas.

➔ **IMPORTANT:** Compatible with all HQ longarm machines equipped with the Handi Feet Mount (except for HQ Infinity). Conversion kits available for early machines that are not Handi Feet compatible: Handi Feet Conversion Kit (QM00841).



8 10940 02446 8

Part # HG00272 • Printed 0620

Made in PRC and Taiwan • Fabriqué en RPC et à Taiwan



WARNING: Cancer and Reproductive Harm

ADVERTENCIA: Cáncer y Daño Reproductivo

www.P65Warnings.ca.gov

CONTINUED FROM FRONT PAGE

INSTALLING AND ALIGNING CLAMP

Install the needle body and clamp over the needle bar thread guide and onto the needle bar. Loosely tighten the screws through the clamp QM10149; this will make it easier to align in the next step.

 **NOTE:** The clamp has an undercut on the inside diameter that accommodates the larger size of the thread guide.

Rotate the clamp until the five needles align with the large hole in the needle plate, centering as close as possible.

Check that the needles clear the plate by carefully turning the machine hand wheel to lower the needle bar/needles through the needle plate hole and tighten the clamp.

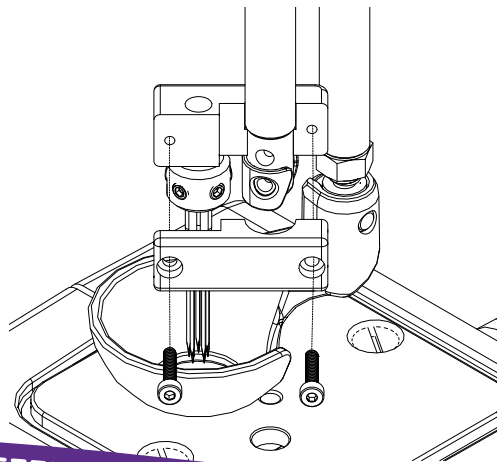

DO NOT ALLOW CHILDREN TO OPERATE!

➔ **IMPORTANT:** Turn the hand-wheel by hand in direction of motion to make sure the needles clear the needle plate properly. **Do not run the machine until you have made this check!**

➔ **IMPORTANT:** The Handi Felting Foot was designed for safety. Use caution when fingers are near the foot. Keep clear of the needles.

For complete operation instructions and tips for needle felting please go to: www.handiquilter.com/felting