

Lift Table Drawer (HG01412)

Assembly Instructions

01/24/23

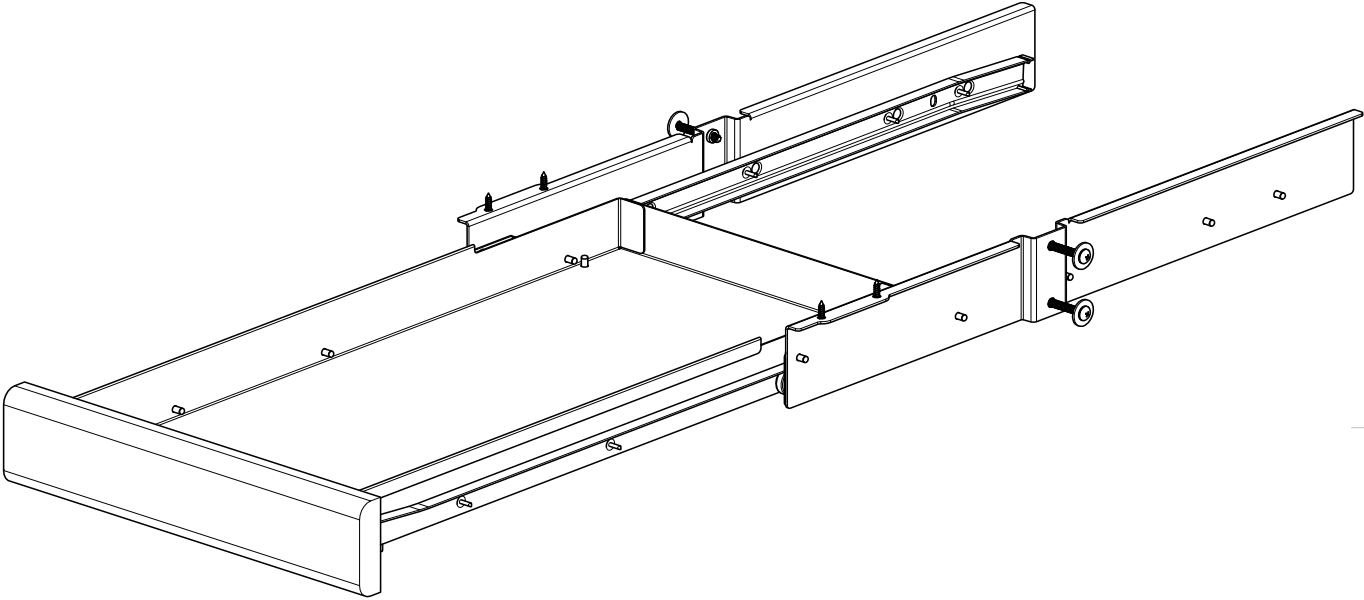

Parts List

HG-01412 Lift Table Drawer Contents

PART #	DESCRIPTION	QTY
HG01412-0101	SD DRAWER PAN ASSEMBLY W/SLIDES ATTACHED	1
HG01412-02	BRACKET-LIFT SIDE MOUNT LEFT	1
HG01412-03	BRACKET-LIFT SIDE MOUNT RIGHT	1
HG01412-04	SD LIFT FRONT FACE	1
QM10724	SCREW-#10-24 X 1.375 PHP	4
QM10717	WASHER-#10 0.688" OD	4
QM10348	SCREW-M3.5 X 8 PHP W ZN	4
QM10381	SCREW-M3.5 X 12 PHP W ZN	4

Tools Needed:

- #2 Phillips Screwdriver - not provided
- If desired drill for pre-drilling holes in top - not provided
- If desired 3/32" bit for drilling holes in top - not provided
- If desired small square to check brackets - not provided

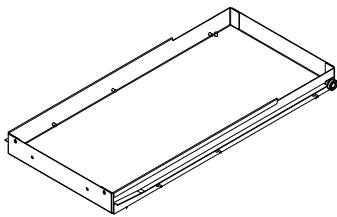

Part # HG01412-0101

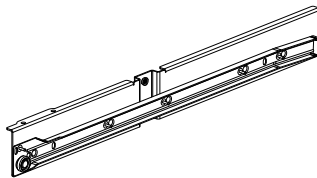

Part # HG01412-02

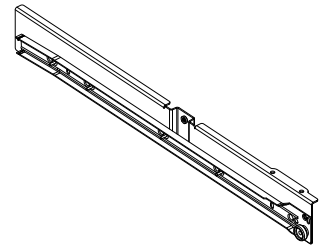

Part # HG01412-03

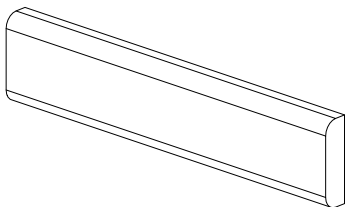

Part # HG01412-04

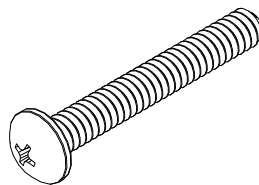

Part # QM10724

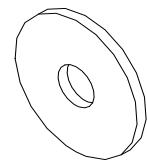

Part # QM10717

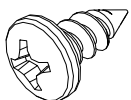

Part # QM10348

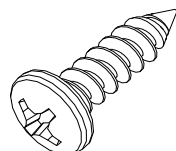

Part # QM10381

Drawer Assembly

1. With the help of a second person carefully unplug the cables to the machine and remove it from the table.

2. Place the drawer front face on a protective surface with the pre-drilled holes facing up.

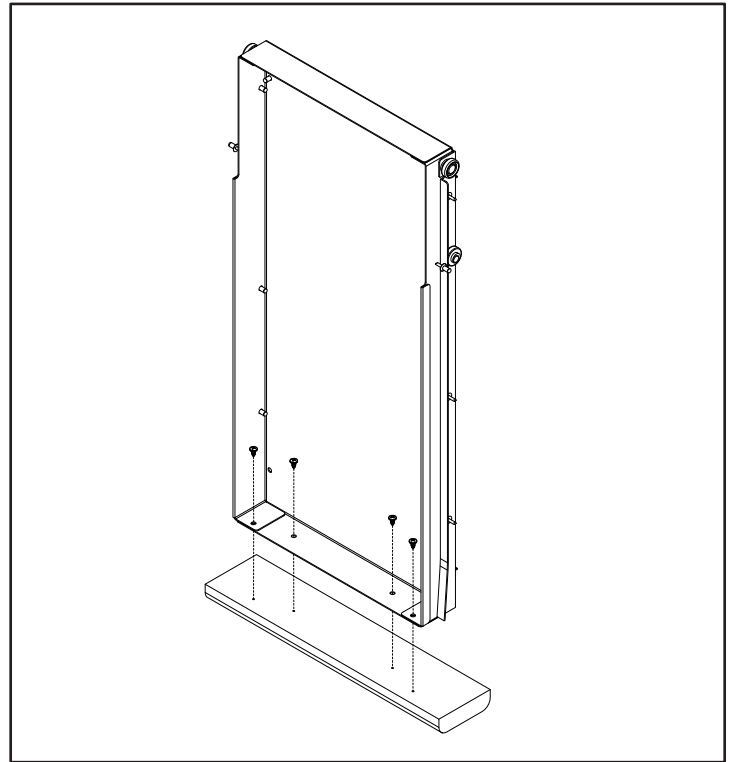

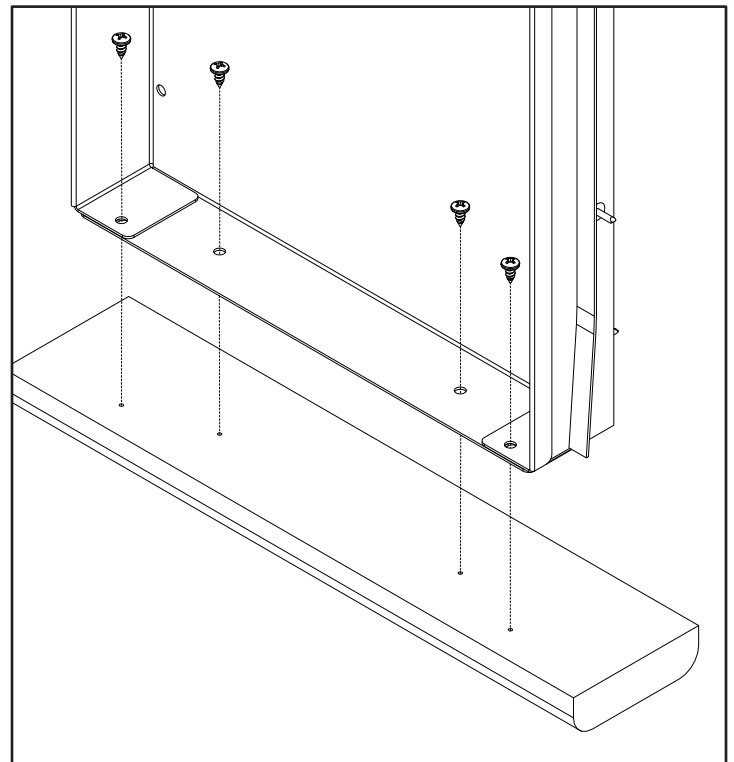

3. Place the pan onto the drawer face aligning the four pre-drilled holes and fasten it with four M3.5 X 8 wood screws using a #2 Phillips screwdriver.





Drawer Assembly - Continued

4. Locate the Bracket-Lift Side Mount Left and Bracket-Lift Side Mount Right. (They are mirror images of each other)

 **NOTE:** The drawer will be mounted on the opposite side from the table lift control switch.

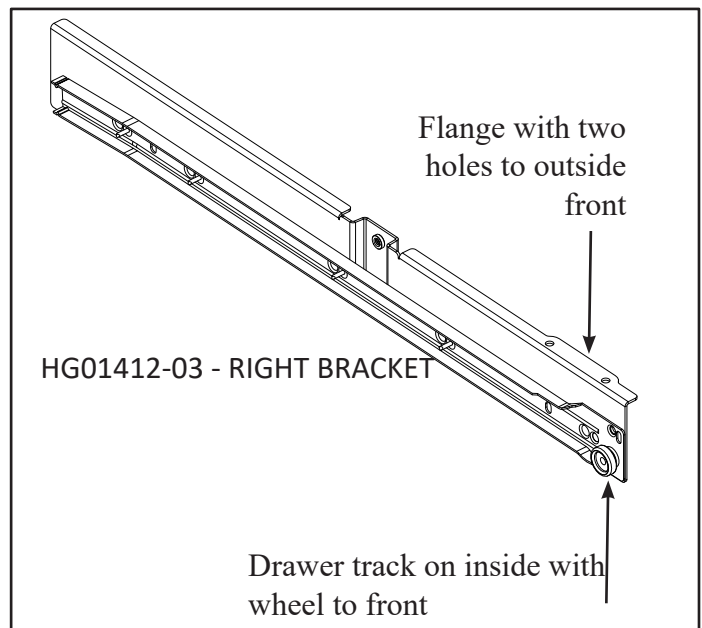
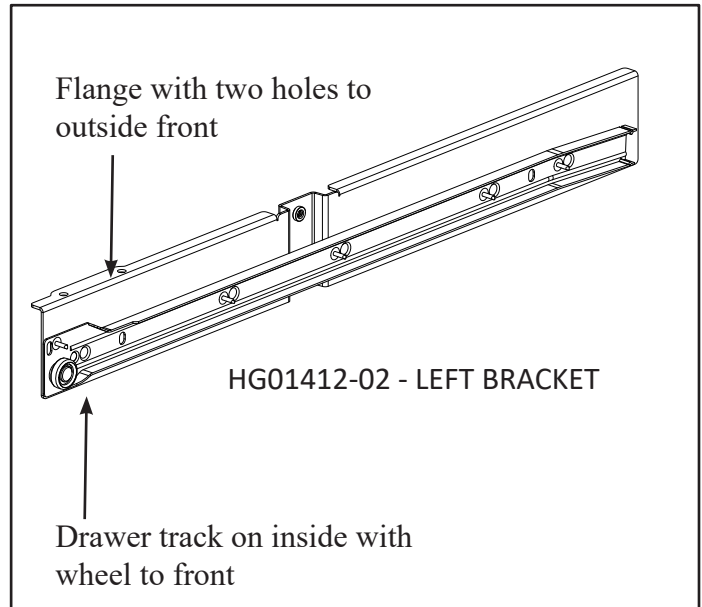
 **NOTE:** Screw heads go from outside of drawer towards inside of drawer



 **IMPORTANT:** If you have a table extension on the side where you want the drawer, the two front table extension screws will need to be removed along with the nut backing plate behind the wood table spacer. The drawer bracket will now be the nut backing plate for the screws. With someone helping support the table extension momentarily, loosen the two front screws, slide out the backing plate, slide the drawer bracket into place and tighten the two screws into the drawer bracket.

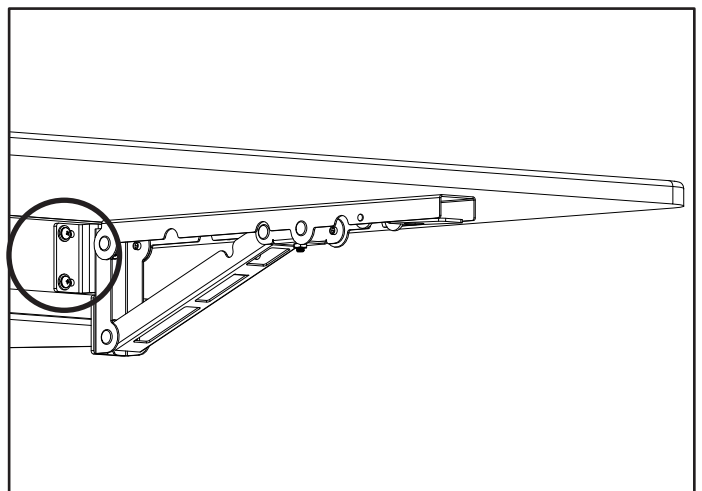

Drawer Assembly - Continued

5. Start with the outside bracket. Place a washer onto two screws and insert them through the two pre-drilled holes in the wooden table spacer and then into the threaded holes in the metal bracket. Start the screws by hand and then tighten them firmly with a #2 Phillips screwdriver.

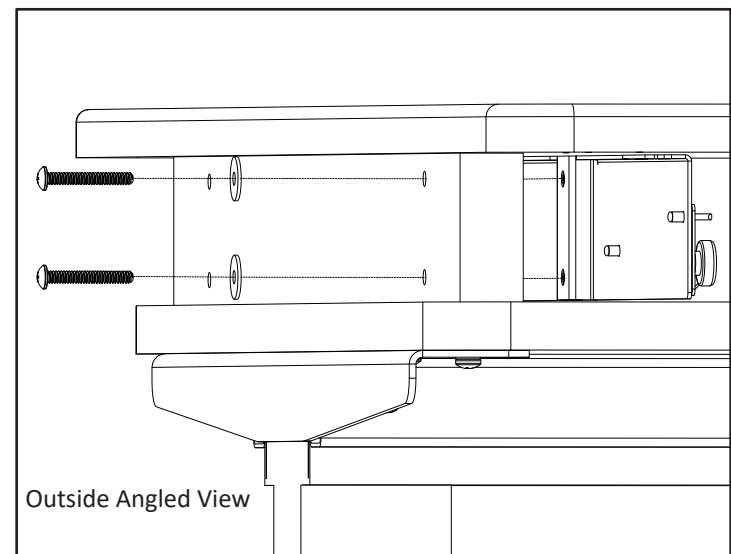
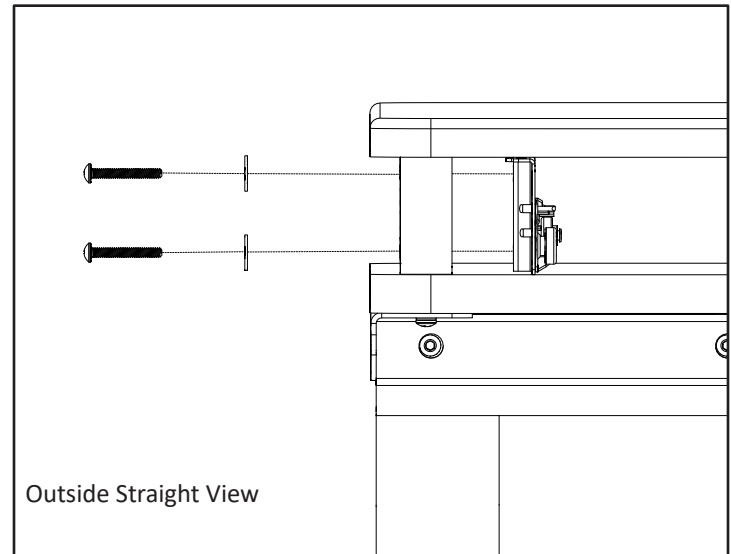

6. Repeat the process from the previous Step for the inside bracket.

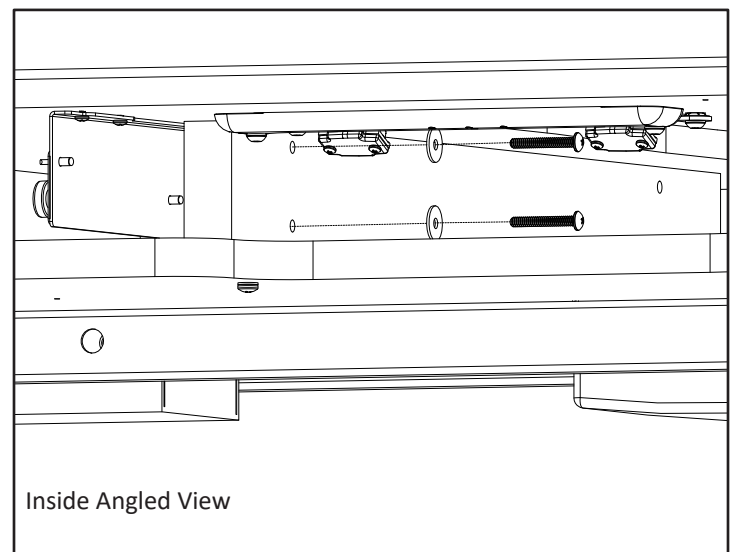

Drawer Assembly - Continued

7. Check that each bracket is straight front to back and perpendicular to the front table edge. A combination square or small square might help with this.
8. Place the drawer pan assembly into the track by lifting the front of the drawer slightly and aligning it with the two brackets while sliding it in.
9. Check the drawer a few times by sliding the drawer in and out to ensure it moves smoothly.

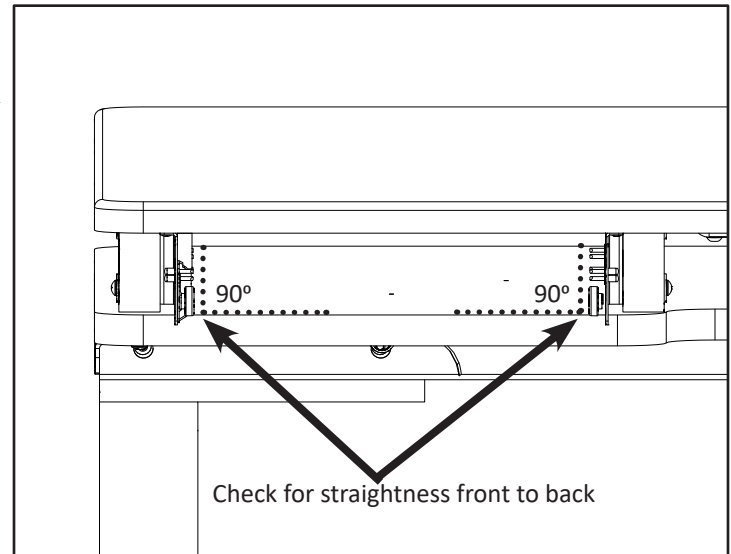

10. Screw two M3.5 X 12 wood screws into the table top at the front of the bracket.

 Note: This may be easier after carefully drilling a 3/32" pilot hole. Be careful not to drill through the table top.

11. Repeat the previous Step for the front of the other bracket.

